

RESOLUTION NO. 3615

AGENDA MEMORANDUM

**Public Entity Partners
FY24 Driver Training Grant**

November 14, 2024

Submitted by:

Cameron McAllister

Administrator of Economic & Community Development

SUBJECT: Approval of FY24 PEP Driver Training Grant

City Administration is asking for the approval from the Mayor and Council to accept the grant award from Public Entity Partners for the FY24 Driver Training Grant program. The City applied for the Driver Training grant in October 2024 and received notification of the award in early November. Public Entity Partners awarded the City \$2,000. However, Public Entity Partners will require the City to spend at least \$4,000 before reimbursing the 50% share.

The grant funds will be utilized to purchase additional GPS vehicle monitors for City owned vehicles within the fleet. The City plans to purchase (14) additional GPS systems to equip vehicles in the City's Sanitation Department, Street Department, Police Department, and Fire Department.

The GPS devices will be paid for up front by grant funds. Monthly reoccurring services fees will be deducted from the appropriate department's budgeted funds.

RESOLUTION NO. 3615

A RESOLUTION OF THE CITY COUNCIL OF THE CITY OF EAST RIDGE, TENNESSEE, AUTHORIZING THE CITY OF EAST RIDGE TO ACCEPT THE FY 2024 PUBLIC ENTITY PARTNERS DRIVER TRAINING GRANT

WHEREAS, the City applied for and was awarded the Public Entity Partners (“PEP”) FY24 Driver Training Grant; and

WHEREAS, the City was awarded a grant amount of \$2,000 but must provide a 50% matching amount of \$2,000; and

WHEREAS, staff is requesting Council approval to accept the PEP grant in the amount of \$2,000 and provide a matching amount of \$2,000; and

WHEREAS, the grant funds will be used to purchase fourteen (14) additional GPS vehicle monitors for City-owned vehicles for the Sanitation Department, Street Department, Police Department, and Fire Department.

NOW, THEREFORE, BE IT RESOLVED by the City Council of the City of East Ridge, Tennessee, as follows:

Section 1. That the City of East Ridge is hereby authorized to accept the PEP Grant in the amount of \$2,000; and

Section 2. That the City of East Ridge is further authorized to provide an amount of \$2,000 to serve as a match for monies provided by this grant.

Section 3. That the grant funds will be used to purchase fourteen (14) additional GPS vehicle monitors for City-owned vehicles for the Sanitation Department, Street Department, Police Department, and Fire Department.

BE IT FURTHER RESOLVED that this resolution shall take effect immediately after its passage, the public welfare of the City requiring it.

Adopted on this the _____ day of _____ 2024.

Brian W. Williams, Mayor

ATTEST:

J. Scott Miller, City Manager

APPROVED AS TO FORM:

Mark W. Litchford, City Attorney

RESOLUTION NO. 3616

AGENDA MEMORANDUM

**APPROVAL FOR THE ADVANCEMENT OF STATE SALARY SUPPLEMENT FOR
FIREFIGHTERS**

November 14, 2024

Submitted by:



Michael Williams, Fire Chief

SUBJECT:

I am requesting that the Mayor and Councilmembers approve the advancement of the State Salary Supplement for all certified career firefighters as in years past. This supplement will be refunded to the City in or around June of 2025.

The amount is for 28 career certified firefighters at \$ 800.00 each and a total amount of \$ 22,400.00

Below is a list of each certified firefighters who receives this state salary supplement after completing the required in service hours.

Jaxon Albright	Randy Albright	Jacob Backer
Daniel Bernard	Eric Bowen	James Burkhart
Alex Chaigne	Brandon Clark	Chris Cope
Roy Cope	Jared Cox	Kory Custer
Bryan Dean	Jeff Duncan	Brandon Dycus
Victor Dzhuga	Tyler Ezell	Thomas Finch
Drew Hannigan	Austin Henager	Kent Henson
Anthony Melasecca	Cory Pauley	Chris Peters
Jess Sloan	Logan Swope	Joshua Williams
Mike Williams		

RESOLUTION NO. 3616

**AGENDA MEMORANDUM
Police Salary Supplement**

November 14, 2024

Submitted By:



Clint Uselton, Chief of Police

SUBJECT:

With the completion of the 2024 In-Service, 44 police officers will be eligible for the salary supplement as authorized by the State of Tennessee.

The POST Commission Office has advised us the salary supplement is \$800 per officer, which equals a total of \$35,200.00 for the East Ridge Police Department.

RESOLUTION NO. 3616

**A RESOLUTION OF THE EAST RIDGE CITY COUNCIL
AUTHORIZING THE ADVANCEMENT OF STATE
SALARY SUPPLEMENT PAYMENTS FOR ELIGIBLE
FIREFIGHTERS AND POLICE OFFICERS**

WHEREAS, the State of Tennessee Commission on Firefighting and the Police Officer Standards Commission authorizes the payment of salary supplements to firefighters and police officers for completing approved annual in-service training; and

WHEREAS, the State Firefighting Commission and the Police Officer Standards Commission have determined that the salary supplement for 2024 for each eligible firefighter and eligible police officer shall be \$800 each; and

WHEREAS, the East Ridge City Council historically advances the salary supplement payments to firefighters and police officers before Thanksgiving and the City is thereafter reimbursed by the Firefighting and Police Commissions; and

WHEREAS, the City has twenty-eight (28) eligible firefighters for a total supplement of \$22,400, and

WHEREAS, the City has forty-four (44) eligible police officers for a total supplement of \$35,200, and

WHEREAS, the total salary supplement for eligible firefighters and police officers for 2024 is \$57,600.

NOW, THEREFORE, BE IT RESOLVED BY THE CITY COUNCIL OF THE CITY OF EAST RIDGE, TENNESSEE, that the City Manager is authorized to advance \$800 in salary supplement payments for 2024 to each eligible firefighter and police officer for the total amount of \$57,600.

BE IT FURTHER RESOLVED that the supplements will be paid before Thanksgiving, to firefighters and police officers, and the City will thereafter be reimbursed by the State of Tennessee.

BE IT FURTHER RESOLVED that this resolution shall take effect immediately after its passage, the public welfare of the City requiring it.

Adopted on this the _____ day of _____ 2024.

Brian W. Williams, Mayor

ATTEST:

J. Scott Miller, City Manager

APPROVED AS TO FORM:

Mark W. Litchford, City Attorney

RESOLUTION NO. 3617

AGENDA MEMORANDUM
Beer Board Nomination and Appointment
Councilmember Cagle

November 14, 2024

Submitted by:



Janet Middleton, City Recorder

SUBJECT:

The term for Beer Board member Roy Keown will expire on November 26, 2024. A new appointment will need to be made for a 3-year term ending November 26, 2027. This is Councilmember Cagle's nomination.

RESOLUTION NO. 3617

**A RESOLUTION OF THE EAST RIDGE CITY
COUNCIL TO APPROVE A NOMINATION BY
COUNCILMEMBER CAGLE TO THE EAST RIDGE
BEER BOARD**

WHEREAS, the East Ridge Beer Board fulfills an important role with regard to the regulation of licensing, sale, storage for sale, distribution for sale, and manufacturing of beer within the City; and

WHEREAS, the City Council appoints certain of its citizens to the City of East Ridge Beer Board in accordance with City Code Chapter 2, Section 8-201; and

WHEREAS, the term for Boardmember Roy Keown is set to expire on November 26, 2024.

WHEREAS, Councilmember Cagle has nominated _____ to serve on the East Ridge Beer Board for the term November 27, 2024 – November 26, 2027.

NOW, THEREFORE, BE IT RESOLVED that the City Council of the City of East Ridge, Tennessee hereby approves the nomination of _____ by Councilmember Cagle to the East Ridge Beer Board for the term of November 27, 2024 – November 26, 2027.

BE IT FURTHER RESOLVED that this Resolution shall take effect immediately after its passage, the public welfare of the City requiring it.

Adopted this _____ day of _____ 2024.

Brian W. Williams, Mayor

ATTEST:

J. Scott Miller, City Manager

APPROVED AS TO FORM:

Mark W. Litchford, City Attorney

RESOLUTION NO. 3618

AGENDA MEMORANDUM

**Beer Board Nomination and Appointment
Councilmember Tyler**

November 14, 2024

Submitted by:

A handwritten signature in blue ink that reads "Janet Middleton". The signature is written in a cursive style and is positioned above a horizontal line.

Janet Middleton, City Recorder

SUBJECT:

The term for Beer Board member Michele Roberts will expire on November 26, 2024. A new appointment will need to be made for a 3-year term ending November 26, 2027. Ms. Roberts was appointed on March 14, 2024 to fill the unexpired term of Shanna Marie. This is Councilmember Tyler's nomination.

RESOLUTION NO. 3618

A RESOLUTION OF THE EAST RIDGE CITY COUNCIL TO APPROVE A NOMINATION BY COUNCILMEMBER TYLER TO THE EAST RIDGE BEER BOARD

WHEREAS, the East Ridge Beer Board fulfills an important role with regard to the regulation of licensing, sale, storage for sale, distribution for sale, and manufacturing of beer within the City; and

WHEREAS, the City Council appoints certain of its citizens to the City of East Ridge Beer Board in accordance with City Code Chapter 2, Section 8-201; and

WHEREAS, the term for Boardmember Michele Roberts is set to expire on November 26, 2024.

WHEREAS, Councilmember Tyler has nominated _____ to serve on the East Ridge Beer Board for the term November 27, 2024 – November 26, 2027.

NOW, THEREFORE, BE IT RESOLVED that the City Council of the City of East Ridge, Tennessee hereby approves the nomination of _____ by Councilmember Tyler to the East Ridge Beer Board for the term of November 27, 2024 – November 26, 2027.

BE IT FURTHER RESOLVED that this Resolution shall take effect immediately after its passage, the public welfare of the City requiring it.

Adopted this _____ day of _____ 2024.

Brian W. Williams, Mayor

ATTEST:

J. Scott Miller, City Manager

APPROVED AS TO FORM:

Mark W. Litchford, City Attorney

RESOLUTION NO. 3619

AGENDA MEMORANDUM

**Appointment of Beer Board Chairperson
Mayor Williams**

November 14, 2024

Submitted by:

Janet Middleton, City Recorder

SUBJECT:

Pursuant to Title 8, Chapter 2, Section 201 of the City Code, the Mayor has the prerogative of naming the Chairperson of the Beer Board each November. The current Chairperson is Roy Keown.

RESOLUTION NO. 3619

**A RESOLUTION OF THE EAST RIDGE CITY
COUNCIL TO MEMORIALIZE THE MAYOR'S
APPOINTMENT OF THE CHAIRPERSON OF THE
EAST RIDGE BEER BOARD**

WHEREAS, the East Ridge Beer Board fulfills an important role with regard to the regulation of licensing, sale, storage for sale, distribution for sale, and manufacturing of beer within the City; and

WHEREAS; it is the prerogative of the Mayor to appoint a Chairperson to the East Ridge Beer Board each November; and

WHEREAS, the Mayor wishes to appoint _____ as Chairperson of the East Ridge Beer Board.

NOW, THEREFORE, BE IT RESOLVED that the City Council of the City of East Ridge, Tennessee hereby memorializes the Mayor's appointment of _____ as Chairperson of the East Ridge Beer Board.

BE IT FURTHER RESOLVED that this Resolution shall take effect immediately after its passage, the public welfare of the City requiring it.

Adopted this _____ day of _____ 2024.

Brian W. Williams, Mayor

ATTEST:

J. Scott Miller, City Manager

APPROVED AS TO FORM:

Mark W. Litchford, City Attorney

RESOLUTION NO. 3620

**AGENDA MEMORANDUM
REPLACEMENT ROOF – MUNICIPAL LIBRARY**

November 14, 2024

Submitted By:



J. Scott Miller, City Manager

SUBJECT:

The roof over the Municipal Library has developed leaks (about 6 areas) in the library shelving, isles, and sitting areas. The City's Building Maintenance Supervisor has checked the roof and has identified several areas where patches were employed over the years to stop the leaks. He has concluded that a new replacement roof is warranted. The area of the roof over the Library totals 4,560 square feet.

There are four (4) roof systems on the City Hall Complex and the one that needs to be replaced is the south roof system (over the Municipal Library). Staff does not particularly recall when this roof was replaced. The best guess would be prior to 2007. A rough quote for this work was in the neighborhood of \$65,000.

The City solicited bids from roofing contractors for the replacement of the roof over the Library. Sealed bids for this roof project were received and opened on October 31, 2024 and the City received seven (7) bids ranging from \$39,995 (AK Roofing and More) to \$98,883 (Ross Services Corp). A list of the bid proposals is attached hereto.

Chris Gilbert, Building Maintenance Supervisor, performed a reference check on the low bidder (AK Roofing and More). Questions asked of the references included quality of work; callbacks and response time; and would they use again/recommend. The results were all positive. A copy of the reference checks is attached hereto.

It is the recommendation of Staff that the bid for the replacement of the roof over the Library be awarded to AK Roofing and More in the amount of \$39,995; as being the lowest, responsible bidder. The City has an appropriation in the Capital Projects Fund (Upgrades to Buildings-Variou Sites) that may be used for major emergency maintenance expenses during the year. The replacement roof over the Library would certainly qualify for the use of these funds.

Attachments

JSM/

RESOLUTION NO. 3620

A RESOLUTION OF THE EAST RIDGE CITY COUNCIL APPROVING A BID FOR THE REPLACEMENT OF A PORTION OF THE ROOF ON THE CITY HALL COMPLEX SPECIFICALLY, THE PORTION OF THE ROOF COVERING THE EAST RIDGE CITY LIBRARY

WHEREAS, on October 10, 2024, the City of East Ridge advertised for bids for replacement of a portion of the roof on the City Hall Complex specifically, the portion of the roof covering the East Ridge City Library; and

WHEREAS, sealed bids were opened and publicly read on October 31, 2024, beginning at 2:00 p.m. at East Ridge City Hall; and

WHEREAS, City staff has maintained a file of the bids which were submitted; and

WHEREAS, after conducting a public bid opening and after reviewing the bid documents, City staff recommends the bid for replacement of a portion of the roof on the City Hall Complex, specifically the Library portion, be awarded to AK Roofing and More in the amount of \$39,995.00.

NOW, THEREFORE, BE IT RESOLVED BY THE CITY COUNCIL OF THE CITY OF EAST RIDGE, TENNESSEE, that the bid for the replacement of a portion of the roof on the City Hall Complex specifically, the portion of the roof covering the East Ridge City Library be awarded to AK Roofing and More in the amount of \$39,995.00, to be paid for from the Capital Projects Fund (Upgrades to Building – Various Sites.)

BE IT FURTHER RESOLVED that the Mayor, or his designee, is hereby authorized to execute any contract or agreement necessary between the City of East Ridge and AK Roofing and More, subject to approval of the City Attorney, in the amount stated herein.

BE IT FURTHER AND FINALLY RESOLVED that this resolution shall take effect immediately after its passage, the public welfare of the City requiring it.

Adopted this _____ day of _____, 2024.

Brian W. Williams, Mayor

Attest:

J. Scott Miller, City Manager

Approved as to Form:

Mark W. Litchford, City Attorney

**CITY OF EAST RIDGE
REPLACEMENT OF ROOF FOR
PORTION OF CITY HALL COMPLEX
(Municipal Library)
BID OPENING: OCTOBER 31, 2024 – 2:00 PM EDT**

BID TABULATION

COMPANY	BID AMOUNT
AK Roofing and More	\$39,995.00
Tri-State Roofing and Contracting, LLC	\$42,680.00
Aspen Contracting, Inc.	\$50,000.00
JDH Company, Inc.	\$50,207.00
Foam-Crete, Inc. of Chattanooga	\$54,304.00
Rackley Roofing Co., Inc.	\$56,187.00
Ross Services Corp.	\$98,883.12

A.K. Roofing References

Chris Mills (Hunter Oil)

(423)-414-7977

2009 S. Highland Park Ave.

- Quality of work:
Performed great work in a reasonable time.
- Callbacks and response time:
Work was performed around 2 years ago and he has had zero issues.
- Would use again/recommend:
They “definitely recommend A.K. and will use again in the future”.

Sam Patel (La Quinta)

(423)-667-7272

Cleveland, TN

- Quality of work:
Used AK Roofing at La Quinta for several TPO jobs, that were all done in a timely manner.
- Callbacks and response time:
Work was performed less than a year ago but has had no callbacks.
- Would they use again/recommend:
Very happy with their work and highly recommend using them.

Bob Smith (Hampton Inn/Sundown Renovations)

(818)-822-4019

Athens, TN

- Quality of work:
He has been using them for the last 8-9 years and says they are fantastic.
- Callbacks and response time:
Anytime they have an issue they come right out and fix it at no cost or hassle.
- Would they use again/recommend:
Highly recommend using them.

RESOLUTION NO. 3621

**AGENDA MEMORANDUM
In-Car Tablet and Mounting Solution**

November 14, 2024

Submitted By:



Clint Uselton, Chief of Police

SUBJECT:

The East Ridge Police Department seeks approval to purchase ten (10) ruggedized windows-based tablets with keyboards and an in-car mounting solution compatible with existing computer mounts.

A request for bid submissions was advertised on October 6, 2024 and two bids were opened on October 22, 2024.

The bid from Midwest Public Safety LLC totaled \$45,340.00.

The bid from Derry Software LLC totaled \$32,726.70.

Staff recommends accepting the bid from Derry Software LLC for \$32,726.70.

The purchase of the tablets was included in the budget.

RESOLUTION NO. 3621

**A RESOLUTION OF THE EAST RIDGE CITY COUNCIL
APPROVING A BID FOR IN-CAR TABLETS AND
MOUNTING SOLUTIONS FOR THE POLICE
DEPARTMENT**

WHEREAS, on October 6, 2024, the City of East Ridge advertised for bids for in-car tablets and mounting solutions for the Police Department; and

WHEREAS, on October 22, 2024, at 2:30 pm, sealed bids were opened and publicly read at East Ridge City Hall; and

WHEREAS, City staff has maintained a file of the bids which were submitted; and

WHEREAS, after conducting a public bid opening and after reviewing the bid documents, City staff recommends the bid for in-car tablets and mounting solutions be awarded to Derry Software LLC in the amount of \$32,726.70.

NOW, THEREFORE, BE IT RESOLVED BY THE CITY COUNCIL OF THE CITY OF EAST RIDGE, TENNESSEE, that the bid for in-car tablets and mounting solutions be awarded to Derry Software LLC in the amount of \$32,726.70.

BE IT FURTHER RESOLVED that the Mayor is hereby authorized to execute any contract or agreement necessary between the City of East Ridge and Derry Software LLC subject to approval of the City Attorney, in the amount stated herein.

BE IT FURTHER AND FINALLY RESOLVED that this resolution shall take effect immediately after its passage, the public welfare of the City requiring it.

Adopted this _____ day of _____, 2024.

Brian W. Williams, Mayor

Attest:

J. Scott Miller, City Manager

Approved as to Form:

Mark W. Litchford, City Attorney

RESOLUTION NO. 3622

**AGENDA MEMORANDUM
SPLASH PAD SHADE STRUCTURE
November 14, 2024**

Submitted By:

Shawwna Skiles

Shawwna Skiles, Parks and Recreation Director

SUBJECT: Approval Request for Splash Pad Shade Structure

The Parks and Recreation Department is seeking Council approval for the purchase and installation of a shade structure for the Splash Pad from Game Time through the Omnia Partners Cooperative Purchasing Program.

Scope of Service:

- **Quantity:** 1
- **Part #:** QRI189
- **Description:** GT-Shade - GTCU080810IG CANTI UMB 8X8X10 with Gold Basic Fabric
- **Installation:** Includes installation of the above shade

Contract: OMNIA #2017001134

Cost Breakdown:

- **Subtotal:** \$13,563.00
- **Discount:** (\$142.29)
- **Freight:** \$578.64
- **Total:** \$13,999.35

This expenditure is a budgeted line item in the Community Center budget.

Attachment included.

SS

RESOLUTION NO. 3622

A RESOLUTION OF THE EAST RIDGE CITY COUNCIL AUTHORIZING THE CITY MANAGER OR HIS DESIGNEE TO PURCHASE AND HAVE INSTALLED A SHADE STRUCTURE FOR THE SPLASH PAD FROM GAME TIME THROUGH THE OMNIA PARTNERS COOPERATIVE PURCHASING PROGRAM, CONTRACT LISTING #2017001134

WHEREAS, the City of East Ridge Parks and Recreation Department is requesting approval for the purchase and installation of a shade structure for the Splash Pad from Game Time through the OMNIA Partners Cooperative Purchasing Program; and

WHEREAS, the City of East Ridge is allowed to purchase through membership in the OMNIA Partners Cooperative Purchasing Program, which uses a competitive solicitation and selection process to bid out a variety of goods, products, and services to local governments, eliminating the need for the City to obtain competitive bids; and

WHEREAS, the total cost of the shade structure from Game Time, including purchase, installation, and freight charges through the OMNIA Partners Cooperative Purchasing Program is \$13,999.35.

NOW, THEREFORE, BE IT RESOLVED BY THE CITY COUNCIL OF THE CITY OF EAST RIDGE, TENNESSEE, that the City Manager is authorized to purchase and have installed a shade structure for the splash pad from Game Time through the OMNIA Partners Cooperative Purchasing Program, Contract Listing #2017001134, without obtaining competitive bids, for a total cost of \$13,999.35.

BE IT FURTHER RESOLVED that this resolution shall take effect immediately after its passage, the public welfare of the City requiring it.

Adopted this _____ day of _____, 2024

Brian W. Williams, Mayor

Attest:

J. Scott Miller, City Manager

Approved as to Form:

Mark W. Litchford, City Attorney



GameTime c/o Cunningham Recreation
 PO Box 240981
 Charlotte, NC 28224
 800.438.2780
 704.525.7356 FAX

10/28/2024
 Quote #
 168914-01-07

City of East Ridge - Splash Pad Shade (Option 4 Revised)

City of East Ridge
 Attn: Shawna Skiles
 1517 Tombras Avenue
 East Ridge, TN 37412
 United States
 Phone: 423-260-9190
 sskiles@eastridgetn.gov

Ship to Zip 37412

Quantity	Part #	Description	Unit Price	Amount
1	QRI189	GT-Shade - GTCU080810IG CANTI UMB 8X8X10 W/GLD [Basic: _____] [Fabric 1: _____]	\$4,743.00	\$4,743.00
1	INSTALL	MISC - Installation of the Above Shade	\$8,820.00	\$8,820.00
Contract: OMNIA #2017001134			Sub Total	\$13,563.00
			Discount	(\$142.29)
			Freight	\$578.64
			Total	\$13,999.35

Comments

- * Site must be clear, level, free of obstructions, and accessible. Site should permit installation equipment access. Purchaser shall be responsible for unknown conditions such as buried utilities, tree stumps, bedrock or any concealed materials or conditions that may result in additional costs.
- * Taxes, if applicable, will be applied at the time of invoice. Please provide a copy of your tax exempt certificate to avoid the addition of taxes.



GameTime c/o Cunningham Recreation
PO Box 240981
Charlotte, NC 28224
800.438.2780
704.525.7356 FAX

10/28/2024
Quote #
168914-01-07

City of East Ridge - Splash Pad Shade (Option 4 Revised)

GAMETIME - TERMS & CONDITIONS:

- **PRICING:** Due to fluctuating economic conditions, pricing is valid for 30 days and is subject to change. Please request updated pricing if your quote is older than 30 days before making a purchase.
- **TERMS OF SALE:** For equipment & material purchases, Net 30 days from date of invoice for governmental agencies and those with approved credit. All others, full payment for equipment, taxes and freight up front. Balance for services & materials due upon completion or as otherwise negotiated upon credit application review. Pre-payment may be required for equipment orders totaling less than \$5,000. Payment by VISA, MasterCard, or AMEX is accepted (**If you elect to pay by credit card, GameTime charges a 2.50% processing fee that is assessed on the amount of your payment. This fee is shown as a separate line item and included in the total amount charged to your credit card. You have the option to pay by check, ACH or Wire without any additional fees.**). Checks should be made payable to Playcore Wisconsin, Inc. dba GameTime unless otherwise directed. **Any order exceeding \$300,000 will require progress payments during the course of completion.**
- **CREDIT APPLICATION:** Required for all non-governmental agencies and those entities who have not purchased from GameTime within the previous twelve calendar months.
- **FINANCE CHARGE:** A 1.5% monthly finance charge (or maximum permitted by law) will be added to all invoices over 30 days past due.
- **CASH WITH ORDER DISCOUNT:** Orders for GameTime equipment paid in full at time of order via check or electronic funds transfer (EFT) are eligible for a 3% cash-with-order (CWO) discount. Consult local sales representative for CWO terms.
- **ORDERS:** All orders shall be in writing by purchase order, signed quotation or similar documentation. Purchase orders must be made out to Playcore Wisconsin, Inc. dba GameTime.
- **FREIGHT CHARGES:** Shipments shall be F.O.B. destination. Freight charges prepaid and added separately.
- **SHIPMENT: Standard Lead time is 6-8 weeks (some items may take longer)** after receipt and acceptance of purchase order, credit application, color selections and approved drawings or submittals.
- **PACKAGING:** All goods shall be packaged in accordance with acceptable commercial practices and marked to preclude confusion during unloading and handling.
- **RECEIPT OF GOODS:** Customer shall coordinate, receive, unload, inspect and provide written acceptance of shipment. Any damage to packaging or equipment must be noted when signing delivery ticket. If damages are noted, receiver must submit a claim to Cunningham Recreation within 15 Days. Receiver is also responsible for taking inventory of the shipment and reporting any concealed damage or discrepancy in quantities received within 60 days of receipt.
- **RETURNS:** Returns are only available on shipments delivered within the last 60 days. A 25% (min.) restocking fee will be deducted from any credit due. Customer is responsible for all packaging & shipping charges. Credit is based on condition of items upon return. All returns must be in unused and merchantable condition. GameTime reserves the right to deduct costs associated with restoring returned goods to merchantable condition. Uprights & custom products cannot be returned.
- **TAXES:** Sales tax is shown as a separate line item when included. A copy of your tax exemption certificate must be submitted at time of order or taxes will be added to your invoice.

INSTALLATION CONDITIONS:

- **ACCESS:** The site must be clear, level, and provide unrestricted access for trucks and machinery. Any site that is inaccessible may incur additional charges.
- **STORAGE:** The customer is responsible for providing a secure area for off-loading and storing equipment during installation. Once equipment is delivered to the site, the owner assumes responsibility for any theft or vandalism unless alternative arrangements are made and documented in the quotation.
- **FOOTER EXCAVATION:** Installation pricing is based on footer excavation through earth/soil only, prior to the installation of drains, subbase, or surfacing. The customer is responsible for any unforeseen conditions such as buried utilities (public or private), tree stumps, rocks, or any other concealed materials or conditions that may result in additional labor or material costs.
- **UTILITIES:** The installer will contact 811 to locate all public utilities before layout and excavation of footer holes. The owner is responsible for identifying any private utilities. Cunningham Recreation and the installer are not liable for any damage to unmarked private utilities.
- **ADDITIONAL COSTS:** Pricing is based on a single mobilization for installation unless otherwise stated. The price includes only the items specified in this quotation. Additional site work or specialized equipment needs may result in price adjustments.
- **SITE CONDITIONS:** The site must have a slope of less than 1.5%. Any excavation or grading required to achieve an acceptable slope is the responsibility of others unless otherwise noted. All demolition and site preparation must be completed before the installation crew is mobilized.
- **GENERAL INSTALLATION NOTES:** Installation will be performed according to the manufacturer's specifications by a GameTime-certified installer. A one-year warranty on all labor is provided from the date of completion. Product warranty and service claims may not include labor.



GameTime c/o Cunningham Recreation
PO Box 240981
Charlotte, NC 28224
800.438.2780
704.525.7356 FAX

10/28/2024
Quote #
168914-01-07

City of East Ridge - Splash Pad Shade (Option 4 Revised)

ACCEPTANCE OF QUOTATION:

Acceptance of this proposal indicates your agreement to the terms and conditions stated herein.

Accepted By (printed): _____ Title: _____

Telephone: _____ Fax: _____

P.O. Number: _____ Date: _____

Purchase Amount: **\$13,999.35**

SALES TAX EXEMPTION CERTIFICATE #: _____

(PLEASE PROVIDE A COPY OF CERTIFICATE)

Salesperson's Signature

Customer Signature

BILLING INFORMATION:

Bill to: _____

Contact: _____

Address: _____

Address: _____

City, State: _____ Zip: _____

Tel: _____ Fax: _____

E-mail: _____

SHIPPING INFORMATION:

Ship to: _____

Contact: _____

Address: _____

Address: _____

City, State: _____ Zip: _____

Tel: _____ Fax: _____

E-mail: _____

CANTILEVER UMBRELLA SHADE

8' x 8' x 10'

MODEL #:
 CU080810IG (With Glide Elbows)
 CU080810IN (Without Glide Elbows)

REF.#	PART DESCRIPTION	QTY.
1	Column - 4" Sq. w/ Mounting Plate	1
2	Cantilever Arm/Crown - 4" Sq. / Ø5" / Ø2 1/2"	1
3	Rafter - Ø2 1/2" Swaged w/ Adjustment Plate	4
4	Strut - Ø1 1/4" Rigid	4
5	Canopy - 8' x 8' w/ Cable Insert	1
6	Hardware Kit	1

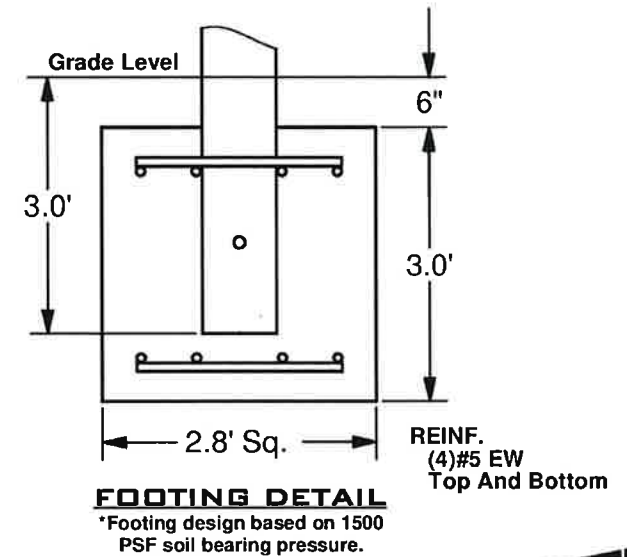
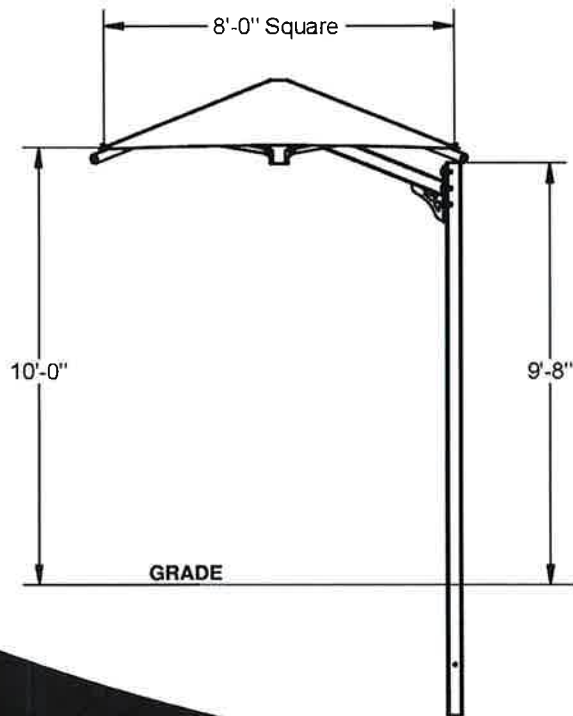
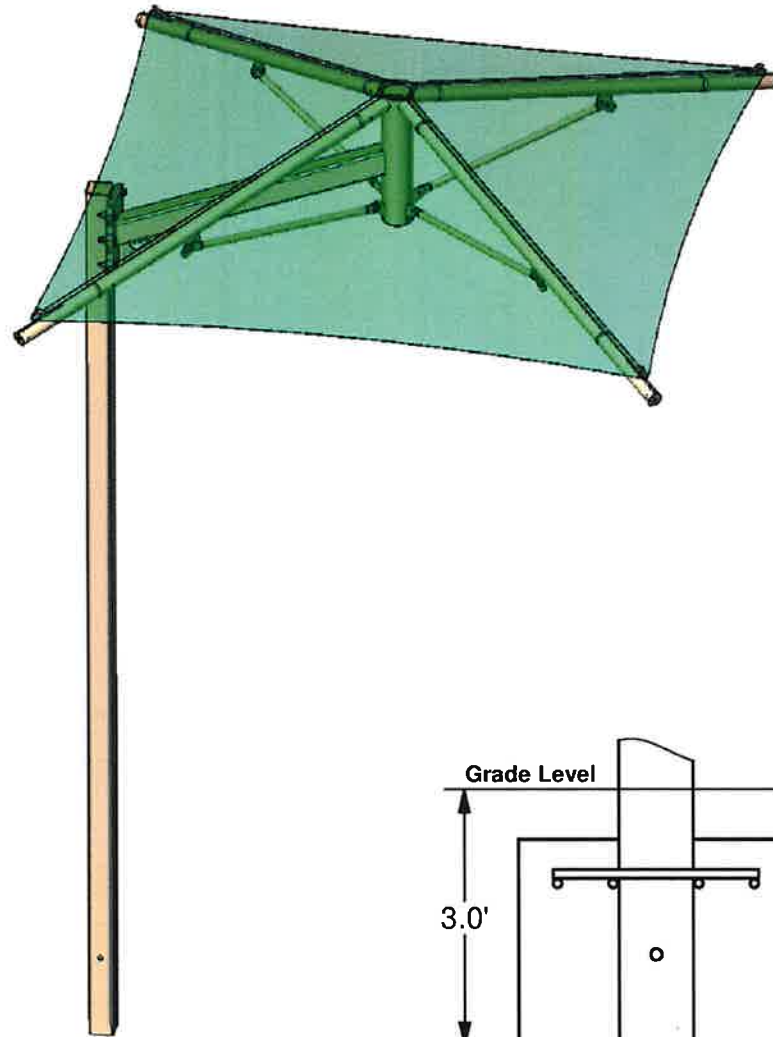

These drawings are for reference only and should not be used as construction details. Materials, fasteners, and foundations are subject to change if professionally sealed engineering drawings are required. Designed for 93 MPH Basic Wind Speed.

RESOLUTION NO. 3623

AGENDA MEMORANDUM

CANCELLATION OF SECOND DECEMBER MEETING

NOVEMBER 14, 2024

Submitted by:



Janet Middleton, City Recorder

SUBJECT:

The second meeting in December falls on the 26th day of the month.

City Council recognizes that its members and city employees wish to spend time with their families over the Christmas holidays. It has been the practice for many years for the City Council to cancel the second meeting in December, if it does not fall on an official holiday, to give everyone the opportunity to enjoy the holidays with their families.

RESOLUTION NO. 3623

**A RESOLUTION OF THE EAST RIDGE CITY
COUNCIL CANCELLING THE DECEMBER 26, 2024
CITY COUNCIL MEETING**

WHEREAS, the East Ridge City Council recognizes that its members and city employees wish to spend time with their families over the Christmas holidays; and

WHEREAS, it has been a long-standing tradition for the Council to cancel the second meeting in December in order for its members and employees to enjoy the holiday season; and

WHEREAS, the City has previously published that a Council meeting was scheduled on December 26, 2024 and desires to approve this Resolution to serve as additional public notice of the Council's decision to cancel said meeting.

NOW, THEREFORE, BE IT RESOLVED that the City Council of the City of East Ridge, Tennessee hereby cancels the City Council meeting scheduled for December 26, 2024.

BE IT FURTHER RESOLVED that this Resolution shall take effect immediately after its passage, the public welfare of the City requiring it.

Adopted this _____ day of _____ 2024.

Brian W. Williams, Mayor

ATTEST:

J. Scott Miller, City Manager

APPROVED AS TO FORM:

Mark W. Litchford, City Attorney

RESOLUTION NO. 3624

**AGENDA MEMORANDUM
STREET RESURFACING PROGRAM**

November 14, 2024

Submitted By:

J. Scott Miller, City Manager

SUBJECT:

The FY 2024-2025 State Street Aid Fund and Capital Improvement Fund has appropriated under Paving/Maintenance the amount of \$1,437,976. A street resurfacing program for this fiscal year was completed by Jeff Sikes, ASA Engineering, Chris Vaughn, Street Department Supervisor, input from the Police Officers, and myself. The three (3) of us went out in the field and visually viewed/inspected the streets and their current condition and developed our listing of streets for consideration for resurfacing.

This fiscal year's street resurfacing program includes portions of residential streets throughout the City that we felt needed attention due to being in a deteriorated condition (spaulding, severe cracking, and/or depression/upheaval in pavement). The residential streets selected are through streets or connecting streets. Cul-de-sac streets were not included in this year's street resurfacing program since there are still many through/connecting streets in poor condition.

Attached hereto please find a listing of streets proposed for the FY 2024-2025 resurfacing program. In many instances only portions, or segments, of the street are scheduled to be milled and resurfaced versus milling and resurfacing the entire street (end to end or intersection to intersection). Following this practice the City is able to mill and resurface additional areas of deteriorated pavement.

The proposed timetable for the street resurfacing program is as follows: City Council approves the list of streets on November 14, 2024; ASA Engineering marks the streets and prepares detailed drawings for bid in November/December 2024; program out to bid in mid-January 2025; and resurfacing to occur after March 1st.

Attachment

JSM/

RESOLUTION NO. 3624

**A RESOLUTION OF THE EAST RIDGE CITY
COUNCIL APPROVING THE STREET
RESURFACING PROGRAM FOR FY 2024-2025**

WHEREAS, the East Ridge City Council wishes to have safe, well-maintained streets in every neighborhood to help ensure the safety of its residents; and

WHEREAS, after visually viewing the streets and their current condition, City staff and ASA Engineering have completed a Street Resurfacing Program for FY 2024-2025 and developed a listing of streets for consideration for resurfacing, attached as Exhibit A; and

WHEREAS, the amount appropriated in the FY 2024-2025 State Street Aid Fund for Paving/Maintenance is \$1,437,976.00; and

WHEREAS, the street resurfacing program entails resurfacing entire streets and portions of streets that are in a deteriorated condition.

NOW, THEREFORE, BE IT RESOLVED BY THE CITY COUNCIL OF THE CITY OF EAST RIDGE, TENNESSEE, that the Street Resurfacing Program for FY 24-25 is hereby approved in the amount not to exceed the budgeted amount of \$1,437,976.00

BE IT FURTHER RESOLVED that this Resolution shall take effect immediately after its passage, the public welfare of the City requiring it.

Adopted as of this _____ day of _____ 2024.

Brian W. Williams, Mayor

Attest:

J. Scott Miller, Interim City Manager

Approved as to Form:

Mark W. Litchford, City Attorney

EXHIBIT A

STREET RESURFACING LIST FY 2024-2025

- Hurst Street – Spring Creek to end
- Wentworth Street – 6017 west to 6009 Wentworth
- Welworth Avenue – Yale to San-His
- Swope Drive – 1400 block of Swope
- Altamaha Street – 1100 and 1300 block of Altamaha
- Marlboro Avenue – 621 to 614, 601, and 507 to 502 Marlboro
- Fountain Avenue – 3611 (manhole area)
- Gleason Drive – 3628 to Gleason Circle and 3200 block of Gleason Drive
- Cathy Lane – 3500 to 3522 Cathy
- Dunlap Avenue – Westonia to Bloom
- Maple Lane – Maple Creek to 607 Maple Lane
- Castle Avenue – 3213 to 3221 Castle
- Poindexter Avenue – 800 to 820 Poindexter
- Sheridan Avenue – Brookhaven to 20 Sheridan and 10 Sheridan to Laurel
- Summit Avenue – 823 to 825 Summit plus intersection
- S. Seminole Drive @ Crabtree Drive – 1235 S. Seminole
- S. Seminole Drive @ Rugby Place – Ten Oaks to Rugby Place
- Reeves Avenue – Bennett to 1217 Reeves
- Fredrick – Phelps to 1309 Fredrick
- Helen Lane – 3610 to 3614 Helen
- Connelly Lane – Intersection of Daniel and 3707 to 3703 Connelly
- Spriggs Street – 4320 to 4329 and 5285 Spriggs to Felton to Prigmore
- Duvall Street – 4329 to 4214 and 1 block off Duvall off Tombras
- Woodard Circle – 7 to 9 and 12 to 25 Woodard
- Swope – Woodward to 1508 and Woodward to Ringgold
- Marietta Street – from Mack Smith to Adair
- Garner Street – N Mack Smith to McDonald
- Intersection of Gleason and Donaldson
- Intersection of Gleason and S Seminole
- Laredo – 1304 to 1300 Laredo
- Tombras Avenue – Lazard to Greenbrier
- Clemens – 5507 to Barry
- State Line – Procter to 1960 State Line and outside lane to Castleberry and curve to Adair
- Jennings – State Line to Hilton
- Lazard – from McBrien to Tombras
- Bluebird Circle – 409 to 414, 429-441, 578-584, and 612 Bluebird
- Driving lane of Stanley Heights Baptist Church adjoining the Animal Shelter
- Roadway for Multi-Purpose Pavilion and Community Center (?)

Scott J. Miller

From: Jeffrey Sikes <jsikes@asaengineeringinc.com>
Sent: Monday, October 21, 2024 11:21 AM
To: Scott J. Miller
Cc: Rachel Tranel; Christian Sawyer
Subject: Roadway Work Estimate for Pavilion Road
Attachments: Pavilion Road Cost Estimate 10212024.xlsx

CAUTION: This email originated from outside the organization and may contain unverified links. Do not click on links or open attachments unless you recognize the sender and know the content is safe.

Good morning, Scott. The roadway work for the pavilion project is estimated to be between \$90k and \$120k. Where we fall within that range is dependent on how far we go to tie into the existing roadway on the northern end of the community center expansion. This includes 780 SY of pavement removal, 1300 SY of 4" thick asphalt pavement and 8" of base stone beneath the pavement. I used unit prices that are at the high end, so this should be a conservative estimate. Add another \$15k to 20k for the sewer relocation needed for the community center expansion if you want to include that work in this estimate.

Let me know if you have questions or if you need additional information. I attached the spread sheet showing the breakdown.

Thank you,

Jeff A. Sikes

Executive Vice-President / Senior Projects Manager

Asa Engineering & Consulting, Inc.

Please Note our New Address

201 Cherokee Blvd., Suite 101

Chattanooga, TN 37405

O: 423.805.3700

C: 423.421.1420

This electronic mail and any files transmitted with it are confidential and are intended solely for the use of the individual or entity to which they are addressed. If you are not the intended recipient or the person responsible for delivering the electronic mail to the intended recipient, be advised that you have received this electronic mail in error and that any use, dissemination, forwarding, printing, or copying of this electronic mail is strictly prohibited. If you have received this electronic mail in error, please immediately notify the sender by return mail.

Asa Engineering & Consulting, Inc. makes no warranty of any kind, express or implied, with respect to the attached file(s). The receiver agrees to indemnify, defend and hold harmless Asa, its officers, and employees from and against any and all claims, suits, losses, damages or costs incurred from using said file(s). The receiver assumes all risk and liability for any losses, damages, claims or expenses resulting from the use or possession of said file(s). Official Survey Drawings, Plan Drawings, and/or Design Files are those paper, mylar, or

Build New Road Within Limits of Comm Center and Pavilion

	SF	SY	CF	CY	Tons	Unit Price	Total
Pavement Removal		7000.0	777.8	0.0	0.0	0.0 \$	4.5 \$ 31,500
8" Base Stone Layer	11719.0		1302.1	7851.7		530.0 \$	45.0 \$ 23,850
2.5" Binder Layer	11719.0		1302.1			179.0 \$	185.0 \$ 33,122
1.5" Surface Layer	11719.0		1302.1			107.4 \$	200.0 \$ 21,485
							<u>TOTAL \$ 109,957</u>

RESOLUTION NO. 3625

AGENDA MEMORANDUM
SOUND ATTENUATION
EAST RIDGE ANIMAL SHELTER

November 14, 2024

Submitted By:

J. Scott Miller, City Manager

SUBJECT:

My office has received complaints from the residents (majority being senior citizens) residing in the apartment complexes adjacent to the east side of the Animal Shelter about the barking of the dogs housed in the dog kennels in the shelter. After the first complaint Chief Uselton and I directed the Animal Control Officers to move the dogs inside during the nighttime hours. I still received complaints from the residents on hearing the dogs barking during the nighttime while they were inside the shelter, and the guillotine doors closed. Chief Uselton and I stood outside of the shelter next to the apartment units early one morning and we could clearly hear the dogs barking from inside the shelter.

Since that time Chief Uselton and I have met with two acoustical professionals on site to discuss remedies that could be implemented to substantially reduce the noise. Each of them mentioned a couple of solutions that could be constructed/installed; ie. hanging of baffles from the ceiling of the dog kennels, installing sound silencer acoustical wall panels, and constructing a sound wall (12-15 feet in height) to be installed on the east side of the shelter. One professional made a written proposal to design a system (inside and outside) for a fee of \$8,500.

Chief Uselton and I contemplated moving forward with the proposal; however, after talking about possible solutions we came to the conclusion that the City should go out and solicit bids for a design-build project proposing: (1) a sound wall be erected on the full east side of the shelter; and (2) **either** sound baffles be installed inside the building hanging from the ceiling (2 per kennel being 3-4 feet in height and 6 feet in width) **or** sound silencer acoustical wall panels be installed on the walls and ceiling of the inside of the building in the dog run hallways.

Chief Uselton and I are not specialists in sound attenuation methods and materials; however, we gained knowledge from the professionals we met with. A ballpark figure for the construction of an outside sound wall and the installation of baffles/acoustical wall panels in the inside could cost in the neighborhood of \$100,000. Funds are available from the balance in the contingency fund of the Animal Shelter project in the amount of \$217,000.

Attachments

JSM/

RESOLUTION NO. 3625

**A RESOLUTION OF THE EAST RIDGE CITY COUNCIL TO
AUTHORIZE THE CITY MANAGER TO ADVERTISE FOR
BIDS FOR A DESIGN-BUILD PROJECT FOR A SOUND
ATTENUATION SYSTEM AT THE EAST RIDGE ANIMAL
SHELTER**

WHEREAS, the City has received complaints from residents that live adjacent to the new Animal Shelter about barking from dogs that are housed in the kennels at the shelter; and

WHEREAS, the City Manager and Police Chief have met with acoustic professionals onsite to discuss remedies that could be implemented to substantially reduce the noise; and

WHEREAS, after discussion of the possible remedies, the City Manager and Police Chief concluded that the City should advertise for solicitation of bids for a design-build project for the sound attenuation of the Animal Shelter; and

WHEREAS, this is not a budgeted item; however, funds are available from the balance in the contingency fund of the Animal Shelter project in the amount of \$217,000.

NOW, THEREFORE, BE IT RESOLVED BY THE CITY COUNCIL OF THE CITY OF EAST RIDGE, TENNESSEE, that the City Manager will be authorized to advertise for solicitation of bids for a design-build project for the sound attenuation of the Animal Shelter.

BE IT FURTHER RESOLVED that the cost for the sound attenuation will come from the contingency fund of the Animal Shelter project.

BE IT FURTHER AND FINALLY RESOLVED that this resolution shall take effect immediately after its passage, the public welfare of the City requiring it.

Adopted this _____ day of _____, 2024.

Brian W. Williams, Mayor

Attest:

J. Scott Miller, City Manager

Approved as to Form:

Mark W. Litchford, City Attorney

Sanitary Baffle

Baffles reduce the reflection of sound waves by adding soft, porous, open-celled materials to an environment. These USDA approved baffles are a durable and virtually rip-proof method of adding sound absorption to reverberant areas. The sound absorption core is completely encapsulated in a reinforced polyester film.

The white facing reflects light, which adds to the illumination in a room. Standard size is 4'x2' with two brass grommets on one four foot side.



- USDA approved
- Washable
- Stain resistant
- NRC rating up to 12.8 per 4'x2' baffle
- Choice of core densities (1.6 lb or 3.0 lb)

Applications:

Typical uses include in food processing plants, bottling lines, clean rooms, hospitals, wineries, swimming pools, animal hospitals, and institutional kitchens.

Product Data:

Description	1.6 lb/ft ³ or 3.0 lb/ft ³ fiberglass core fully encapsulated in a virtually rip-proof reinforced white reinforced polyester film.
Nominal thickness	Type "A" -1 ½" : Type "B" -2"
Standard sizes	48" x 24"
Temperature Range	-40° to +220° F

Acoustical Performance:

(SABINS per 4'x2' baffle)

Product	OCTAVE BAND FREQUENCIES (Hz)						NRC
	125	250	500	1000	2000	4000	
Type "A"	1.15	5.26	8.00	10.9	9.34	5.50	8.40
Type "B"	1.00	8.09	14.65	15.72	12.68	4.93	12.8

Test method: ASTM C423-90a and C423-81



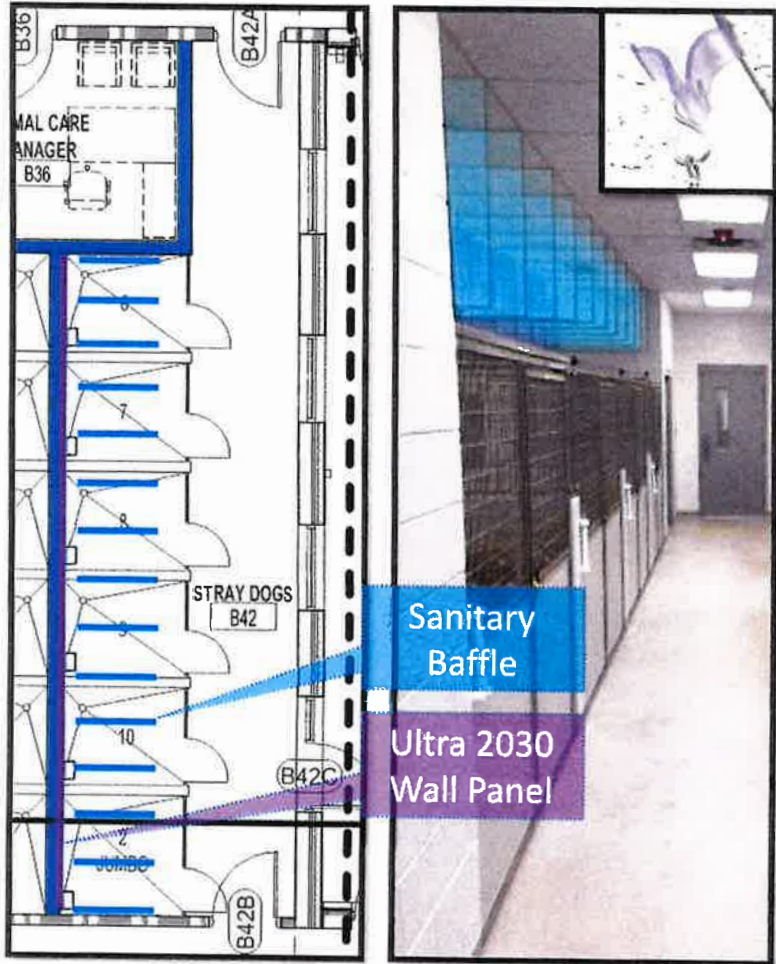

Chattanooga Humane Society Acoustical Quote – TEST ROOM

- **Location:** Stray Dogs B42
- **Material:** Sound Seal
 - Walls – Ultra 2030 Wall Panel
 - Ceiling – Sanitary Baffles
- **Kennel Wall:** (7) 3' x 4'
 - **Pricing:** \$120 ea. x (7) pcs = \$840.00
- **Ceiling:** (15) 4' x 2'
 - **Pricing:** \$60 ea. x (15) pcs = \$900.00
- **Shipping Pricing:** TBD



Sound Silencer (PEPP)

Acoustical Wall & Ceiling Panels

Sound Silencer

Sound Silencer acoustical wall panels are unique – made from Rigid Porous ARPRO Acoustical (P.E.P.P.) Planks, these panels are Class A fire rated with STC and NRC values. Sound Silencer panels are great for gymnasiums, ice rinks, swimming pools, clean rooms, laboratories, food prep areas, firing ranges, and anywhere else where noise control is important. Panels can be applied directly on wall and ceiling surfaces for attractive and effective sound control.

FEATURES & BENEFITS

- High performance – both STC & NRC ratings
- Class A fire rated per ASTM E84
- No fiberglass – non-fibrous
- Water-resistant indoor
- Non-abrasive surface
- Indoor/outdoor usage
- Tackable surface
- Moisture-, impact-, bacteria- & fungi-resistant
- Lightweight & cleanable

Sound Silencer (PEPP) Acoustical Wall & Ceiling Panels



Sound Absorption

	Mount	125Hz	250Hz	500Hz	1KHz	2KHz	4KHz	NRC
Sound Silencer 1"	Wall - A Mount	0.05	0.06	0.21	0.80	0.65	0.75	0.45
Sound Silencer 1"	with 1" Echo Eliminator	0.11	0.58	1.07	0.71	0.74	0.72	0.80
Sound Silencer 2"	Wall - A Mount	0.07	0.21	0.81	0.85	0.93	0.88	0.70
Sound Silencer 2"	Wall with 1" Echo Eliminator	0.17	0.81	0.97	0.85	0.89	0.92	0.90

Sound Transmission Loss*

	125Hz	250Hz	500Hz	1KHz	2.5KHz	5KHz	*STC Rating
Sound Silencer 1"	6	5	7	8	10	15	9
Sound Silencer 2"	9	8	10	10	17	22	13

APPLICATIONS

Gymnasiums, auditoriums, classrooms, offices, swimming pools, ice arenas, clean rooms, food processing plants, food prep areas, cafeterias, restaurants, manufacturing plants, pro audio, car washes, rooftop and machine enclosures, dog kennels, locker rooms and more.

MATERIAL

Semi-rigid porous expanded polypropylene acoustical bead foam (P.E.P.P.). Fiber-free.

SIZES & DIMENSIONS

Standard Wall or Ceiling Panels: 2' x 2', 2' x 4'

Standard Ceiling Tiles: 23-3/4" x 23-3/4", 23-3/4" x 47-3/4"

Custom sizes available up to 25" x 49"

WEIGHT

1" = 1/4 lb./sf 2" = 1/2 lb./sf.

COLORS

White, Charcoal.

FLAMMABILITY

Class A Fire Rating per ASTM E84.

INSTALLATION

ASI Acoustical Adhesive, screws, Z-Clips.





SOUND ABSORBERS

Spec Data Sheet

ULTRA-SERIES FIBERGLASS ABSORBERS

Ultra-2030 Wall Panel (*Ultra Encapsulated, 2", 3.0- lb den.*)

Sound Seal's Ultra Wall Panels absorb sound waves by adding soft, porous, open-celled materials to any environment. The Ultra Wall panel achieves this with a durable, cleanable, and virtually rip-proof facing. The 2" thick, 3-lb. pcf density fiberglass sound absorption core is totally encapsulated on all sides by a scrim reinforced aluminized polypropylene facing. There are a number of mounting options available. These panels have a Class A flammability rating per ASTM E-84.

- Class A Flammability Rated
- Durable, Washable
- Puncture and Stain resistant
- NRC .95
- Available in a Silver or White color

Applications:

Typically used in clean rooms, swimming pools, hospitals, kennels, warehouses, factories, or anywhere that requires panels to be steam cleaned. In addition these panels are commonly specified for use in mechanical rooms, wastewater treatment plants and blower buildings to reduce reverberation and overall noise levels.

Product Data:

Description	Nominal 3.0 lb/ft ³ fiberglass core wrapped in a scrim reinforced aluminized polypropylene facing.
Nominal thickness	2.0 inches
Fiberglass Density	3 lbs. per cu. ft.
Standard size	4' x 8'
Temperature Range	40° to +265° F

Acoustical Performance:

Sound Absorption Data

Product	OCTAVE BAND FREQUENCIES (Hz)						
	125	250	500	1000	2000	4000	NRC
UE-2030	.28	.86	1.10	1.00	.76	.45	.95

Per ASTM C-423



BBC-EXT-R-2 Lb Sound Curtains

BBC- EXT-R-2 Lb offers the benefits of both a noise barrier and a sound absorber composite in one product for outdoor applications. This barrier-backed product consists of an exterior grade, UV resistant heavy-duty faced quilted fiberglass absorber bonded to a two-pound per sq. ft. reinforced loaded vinyl barrier. Modular curtain panels are constructed with grommets across the top and bottom, and exterior grade Velcro seals along the vertical edges. Modular panels are sewn with an exterior grade thread. The product is also available in roll form with edges bound or unbound.

- STC 38 Rating, NRC .65
- Available facing colors on quilt: gray, tan, black, off-white
- Available barrier colors: gray, tan, olive drab or blue



Applications:

Typically used as modular curtain panels on long-term construction projects or permanent outdoor applications such as enclosing HVAC equipment, dust collectors or similar machinery behind a manufacturing plant where UV and abuse resistance as well as maximum durability, longevity and noise reduction is required. Also available with a two-inch thick quilted fiberglass absorber, or with a one-pound per sq. ft. reinforced barrier.

Product Data:

Description	Vinyl coated polyester faced 1" quilted fiberglass/ 2 lb-psf reinforced loaded vinyl barrier
Nominal thickness	1.0 inches
Temperature range	-20° to +180° F
Standard panel width	54" wide, lengths as required up to 20' high
Weight	2.2 lb psf

Acoustical Data:

Sound Transmission Loss:

Product	OCTAVE BAND FREQUENCIES (Hz)						STC
	125	250	500	1000	2000	4000	
BBC-EXT-R-2LB	18	26	38	48	52	56	38

ASTM E-90 & E 413

Sound Absorption Performance:

Product	OCTAVE BAND FREQUENCIES (Hz)						NRC
	125	250	500	1000	2000	4000	
BBC-EXT-R-2LB	.18	.68	.74	.72	.42	.29	.65

ASTM C 423

EXTERIOR GRADE NOISE CONTROL PRODUCTS

SOUND SEAL

www.soundcurtains.com

PERMANENT STYLE SOUND CURTAINS

"Most Durable"

BBC-EXT-R Style

BBC-EXT-R Sound Curtain Panels feature our durable reinforced noise barrier and a UV and tear resistant exterior grade faced quilted fiberglass sound absorber sewn with a Gore Tenera exterior grade thread.

- For use on permanent outdoor installations
- 1 lb. psf or 2 lb. psf reinforced noise barrier
- Wind Load > 120 mph
- 1"-thick or 2"-thick quilted fiberglass sound absorber
- STC values ranging from 29 to 38
- NRC values ranging from .65 to .75

Applications...

- HVAC Equipment
- Compressors, Generators
- Dust Collectors
- Shredders

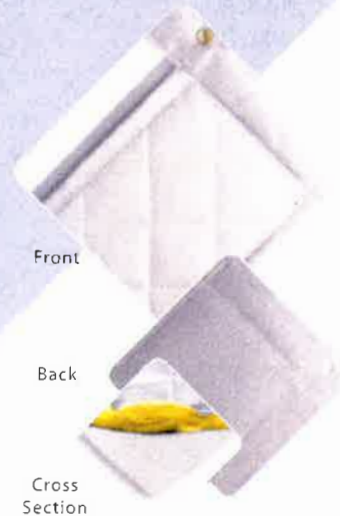

BBC-EXT-R-2" Sound Curtains enclose pumps and compressors.



BBC-13X-2" Sound Curtains were specified on Boston's "Big Dig" project

RESOLUTION NO. 3626

AGENDA MEMORANDUM

**Local Parks & Recreation Fund Grant
Kimley-Horn and Associates, Inc.
Change Order #1**

November 14, 2024

Submitted by:

Cameron McAllister

Administrator of Economic & Community Development

SUBJECT: Approval of Change Order #1 to Professional Services Agreement with Kimley-Horn and Associates, Inc.

City Administration is asking for the approval from the Mayor and Council to accept Change Order #1 to the Professional Services Agreement approved by the City Council (Resolution No. 3550) on May 23, 2024, between the City of East Ridge and Kimley-Horn and Associates, Inc. The Professional Services Agreement provided by Kimley-Horn includes project management, design, and construction plan services, bid phase services, limited construction administration, and grant administration for the East Ridge Community Center renovation. The total cost for the approved agreement was \$160,000.

Change Order #1 dated November 11, 2024, to the agreement between the City of East Ridge, Tennessee ("Client") and Kimley-Horn and Associates, Inc. ("Consultant") dated May 16, 2024 ("the Agreement") concerning East Ridge Community Center (the "Project"). The Consultant has entered into the Agreement with Client for the furnishing of professional services, and the parties now desire to amend the Agreement. The Agreement is amended to include services to be performed by Consultant for compensation as set forth below in accordance with the terms of the Agreement, which are incorporated by reference.

Change Order #1 will include ceiling replacement and fire protection design services. Kimley-Horn and its subconsultant will prepare construction drawings for the demolition and replacement of the ceiling in the entire portion of the building outside of the gym, multi-purpose room, and kitchen preparation area.

Construction drawings will be prepared for mechanical, electrical and fire protection related to this area. Associated fees for Change Order #1 total \$7,500. The additional fee will be paid out of the FY25 Parks & Recreation budget.

RESOLUTION NO. 3626

A RESOLUTION OF THE EAST RIDGE CITY COUNCIL AUTHORIZING THE CITY MANAGER TO APPROVE THE ATTACHED CHANGE ORDER REQUEST #1 TO THE PROFESSIONAL ENGINEERING, PLANNING, AND DESIGN SERVICES AGREEMENT WITH KIMLEY-HORN AND ASSOCIATES, INC.

WHEREAS, on May 23, 2024, Kimley-Horn and Associates, Inc. was approved to provide professional engineering, planning, and design services for the Community Center renovation project; and

WHEREAS, Kimley-Horn and Associates, Inc. is requesting a change order to the original agreement to include ceiling replacement and fire protection design services; and

WHEREAS, the cost of Change Order #1 is \$7,500.00; and

WHEREAS, the City Council deems the completion of the project, including the additional funds for Change Order #1, to be in the best interest of the citizens of East Ridge.

NOW, THEREFORE, BE IT RESOLVED BY THE CITY COUNCIL OF THE CITY OF EAST RIDGE, TENNESSEE, that the City Manager is authorized to approve Change Order Request #1 from Kimley-Horn and Associates, Inc. in the amount of \$7,500 to include ceiling replacement and fire protection design services.

BE IT FURTHER AND FINALLY RESOLVED that this Resolution shall take effect immediately after its passage, the public welfare of the City requiring it.

Adopted this _____ day of _____ 2024.

Brian W. Williams, Mayor

Attest:

J. Scott Miller, City Manager

Approved as to Form:

Mark W. Litchford, City Attorney

AMENDMENT NUMBER 01 TO THE AGREEMENT BETWEEN CLIENT AND KIMLEY-HORN AND ASSOCIATES, INC.

This is Amendment number 01 dated November 11, 2024 to the agreement between East Ridge, Tennessee ("Client") and Kimley-Horn and Associates, Inc. ("Consultant") dated May 16, 2024 ("the Agreement") concerning East Ridge Community Center (the "Project").

The Consultant has entered into the Agreement with Client for the furnishing of professional services, and the parties now desire to amend the Agreement.

The Agreement is amended to include services to be performed by Consultant for compensation as set forth below in accordance with the terms of the Agreement, which are incorporated by reference.

Consultant will perform the following services:

Task 6 – Ceiling Replacement and Fire Protection Design Services

Kimley-Horn and its Subconsultant will prepare construction drawings for the demolition and replacement of the ceiling in the entire portion of the building outside of the gym, multi-purpose room, and kitchen preparation area. Construction drawings will be prepared for mechanical, electrical and fire protection related to this area.

For the services set forth above, Client shall pay Consultant the following compensation:

Task 6 - Ceiling Replacement and Fire Protection Design Services: \$7,500

CLIENT:

By: _____

Title: _____

Date: _____

CONSULTANT:

KIMLEY-HORN AND ASSOCIATES, INC.

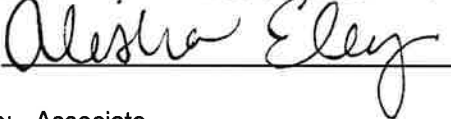
By:  _____

Title: Associate

Date: November, 11, 2024

RESOLUTION NO. 3627

AGENDA MEMORANDUM
SALE OF FLOOD PROPERTY
5.89 ACRES OWNED BY CITY OF EAST RIDGE

November 14, 2024

Submitted By:



J. Scott Miller, City Manager

SUBJECT:

At the June 27, 2024 regular business meeting I brought forth to the City Council a request from a resident living at the end of Jordan Run Road to purchase a 5.89 acre parcel of land that is owned by the City of East Ridge. Said property adjoins his property to the east and is located predominantly in the 100-year flood zone. There is a sliver of land that runs the entire length of the northern edge of the parcel that abuts the creek that is located in the floodway zone. Please see the attached map for details. Also, please see the attached agenda memorandum dated June 27, 2024 for additional information on this subject.

The City Council was amenable to the proposal of the resident and provided the City Manager authorization to obtain an appraisal from Appraiser Shannon Spillman, High Rock, for the 5.89 acre of land at a cost of \$1,200; provided that the appraisal cost of \$1,200 be borne by the resident.

The appraisal completed by Mr. Spillman estimated the “as is” market value of the subject property as of July 8, 2024 to be \$35,000. Based on the land value comparisons the range of adjusted values were as follows:

- Maximum at \$76,500
- Average at \$35,899
- Minimum at \$17,578

The property owner and my office have exchanged emails back and forth in an attempt to reach a reasonable cost of the land. Please take into consideration that the City has no use or plans for this land. The property owner’s last offer was \$16,800 for the land (equates to \$2,852.29 per acre) plus the appraisal fee of \$1,200; for a grand total of \$18,000. Should the City Council accept said amount for the land I would recommend that a condition be drafted in the deed that no structure of any sort ever be built on any portion of the lands.

Attachments

JSM/

RESOLUTION NO. 3627

**A RESOLUTION OF THE EAST RIDGE CITY COUNCIL
AUTHORIZING THE SALE OF 5.89 ACRES LOCATED
ADJACENT TO JORDAN RUN ROAD**

WHEREAS, the City of East Ridge owns a 5.89-acre parcel of land which is adjacent to Jordan Run Road; and

WHEREAS, the City has been approached by a resident who has property located adjacent to the 5.89-acre parcel and wishes to purchase the parcel; and

WHEREAS, the City Council approved the City Manager obtaining an appraisal of the property from Appraiser Shannon Spill which came in at the amount of \$35,000; and

WHEREAS, the property owner who is interested in purchasing the property has offered the City \$16,800 for the property plus \$1,200 for the reimbursement of the appraisal fee for a total of \$18,000.

NOW, THEREFORE, BE IT RESOLVED BY THE COUNCIL OF THE CITY OF EAST RIDGE, TENNESSEE, that the City Council hereby authorizes the sale of the property for \$16,800 and the reimbursement to the City for the appraisal fee of \$1,200 for a 5.89-acre parcel of land located adjacent to Jordan Run Road for a total of \$18,000.

BE IT FURTHER RESOLVED that this Resolution shall take effect immediately after its passage, the public welfare of the City requiring it.

Adopted this _____ day of _____ 2024.

Brian W. Williams, Mayor

Attest:

J. Scott Miller, City Manager

Approved as to Form:

Mark W. Litchford, City Attorney

GISMO 5

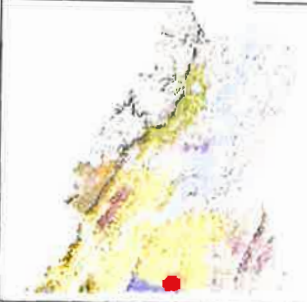

Legend
Parcels

NAD_1983_StatePlane_Tennessee_FIPS_4100_Feet
© Latitude Geographics Group Ltd.



Disclaimer: This map is to be used for reference only, and no other use or reliance on the same is authorized. This map was automatically generated using HCGIS Mapping System. Parcel lines are shown for reference only and are not intended for conveyances, nor is it intended to substitute for a legal survey or property abstract.



August 6, 2024

City of East Ridge
1517 Tombras Avenue
East Ridge, TN, 37412

Vacant Land
On 5.8900 Acres (256,568 SF) Site
Eads St
Chattanooga, Hamilton County, TN 37412

Dear Client,

In accordance with your instructions and authorization, concerning property summarized above and described throughout this document, we have developed this report in order to estimate the current 'As Is' market value of the subject property. The property rights appraised includes the Fee Simple.

The method of valuation, together with the pertinent facts and data gathered in our investigation, is detailed in the attached Appraisal Report. The analysis that forms the basis of this report was conducted by the undersigned. This appraisal assignment was not contingent upon the reporting of a requested minimum or maximum value, a specific valuation or the approval of a loan.

The appraisal is intended to be in compliance with the appraisal requirements of City of East Ridge, and the 2024-2025 Uniform Standards of Professional Appraisal Practice (USPAP) promulgated by the Appraisal Standards Board of the Appraisal Foundation, and Title XI of the Federal Institutions reform, Recovery, and Enforcement Act of 1989 (FIRREA), revised June 7, 1994. Based on the intended users understanding of the subject's physical, economic and legal characteristics, and the intended use of this appraisal, an Appraisal report format was used. This is an Appraisal Report as defined by Uniform Standards of Professional Appraisal Practice under Standards Rule 2-2(a). This format provides a summary or description of the appraisal process, subject and market data and valuation analyses. . The reader's attention is directed to the section of the report concerning Scope of Work for detail concerning the research and analyses performed.

In valuing the subject property, the cost approach was not developed; the sales approach was developed; the income approach was not developed. As is the case in this report, when an approach is not considered, a full explanation for the departure is addressed in the Scope of Work.

Based on the inspection of the property and the investigation and analyses undertaken, the estimated "**as is**" market value of the subject property, as of July 8, 2024, is:

Thirty-Five Thousand Dollars
(\$35,000)

The preceding value conclusions are subject to the following Extraordinary Assumptions and Limiting Conditions. It should be noted that the use of an extraordinary assumption might have affected assignment results:

Hypothetical Conditions

1. There are no hypothetical conditions for this appraisal.

Extraordinary Assumptions

1. No drainage, subsoil, geological, environmental, or engineering reports relative to the subject property were supplied to the appraiser/s. Therefore, this appraisal is contingent upon no adverse conditions being present.

Respectfully submitted,

Michael S. Spillman, MAI
License: TN – CG 4736
GA – CG 268607
AL – CG – G01149

Land Value Conclusion

LAND VALUE CONCLUSION					
	Price per Acre	Gross Adjustment %	Net Adjustment %	Adjusted Conclusions	Final Conclusion
SALE 1	\$30,201	0.00%	0.00%	\$32,231	
SALE 2	\$16,471	0.00%	0.00%	\$17,578	
SALE 3	\$28,926	0.00%	0.00%	\$30,620	
SALE 4	\$85,714	15.00%	-15.00%	\$76,500	
SALE 5	\$21,667	0.00%	0.00%	\$22,566	
Conclusion Summary					
Range of Adjusted Values					
Maximum	Average	Minimum			
\$76,500	\$35,899	\$17,578			
Final Land Value Per unit of Comparison			Price per Acre		\$30,000
Subject (UOC) Unit of Comparison			Acres		1.17
SUB TOTAL					\$35,100
LAND VALUE CONCLUSION					\$35,000

Based on the detailed analysis, as of July 8, 2024 I have reconciled to a sales approach land value of:

Thirty-Five Thousand Dollars
(\$35,000)

AGENDA MEMORANDUM
CAMP JORDAN RENOVATIONS
December 12, 2024

Submitted By:

Shawwna Skiles

Shawwna Skiles, Parks and Recreation Director

SUBJECT: CAMP JORDAN RENOVATIONS

The City of East Ridge is accepting sealed bids for renovation of two restrooms and the interior painting of Camp Jordan Arena. Sealed bids will be received by Janet Middleton, City Recorder, at East Ridge City Hall, 1517 Tombras Avenue, East Ridge, TN 37412 until 2:30 p.m., EST on Wednesday, November 20, 2024, at which time all bids will be opened and publicly read.

SS

AGENDA MEMORANDUM
PURCHASE OF POLE-MOUNTED SIGNAL CABINET
FOR TRAFFIC CONTROL DEPARTMENT

December 12, 2024

Submitted by:

Jeff Crowe

Traffic Control Supervisor

SUBJECT: Purchase of One Pole-Mounted Traffic Signal Cabinet

The Traffic Control Department is requesting approval for the purchase of one pole-mounted traffic signal cabinet assembly from Temple Inc. Temple Inc. supplied all signal cabinets for the 2013-2014 traffic signal upgrade on Ringgold Rd., so the new signal cabinet must be compatible with existing cabinets. This will be a direct replacement for any damaged or non-working pole-mounted signal cabinets City-wide and maintain the use of replacement parts currently in stock with the Traffic Control Department. This assembly will be put into inventory for emergency use.

Purchase Price \$15,149.00

Specifications:

8Ø Cabinet Assembly to include:

EPAC3108M62 Controller

MMU2-16LE Monitor

TF4212 Terminal Facility (12 LS positions)

EL704S2 Pole Mount Cabinet Assembly

Detection Card Rack with power supply

(3) ORACLE2E two channel detectors

(12) Load switches

NEMA Flasher

(4) Flash transfer relays

AGENDA MEMORANDUM
LIBRARY BOARD NOMINATION
AND APPOINTMENT
COUNCILMEMBER TYLER

December 12, 2024

Submitted by:



Janet Middleton, City Recorder

SUBJECT:

The Library Board consists of seven members. The Mayor and each Councilmember nominate one member to the Board, to be approved by the Council. The two remaining positions are open to nominations by the Mayor and entire Council, then approved by the Council.

Board members may serve two (2) consecutive terms and may be reappointed after a minimum three-year break in service.

The term for Kimberly Meyers is scheduled to expire on December 30, 2024. Ms. Meyers was appointed in November 2023 to fill an unexpired term. The term for the new appointment will be from December 31, 2024 – December 30, 2027. This is Councilmember Tyler's nomination.

Brian Williams
Mayor

Esther Haynes
Vice Mayor

Jacky Cagle
Councilmember

Andrea Witt
Councilmember

David Tyler
Councilmember

J. Scott Miller
City Manager

AGENDA MEMORANDUM
LIBRARY BOARD NOMINATION
AND APPOINTMENT
COUNCILMEMBER EZELL

December 12, 2024

Submitted by:



Janet Middleton, City Recorder

SUBJECT:

The Library Board consists of seven members. The Mayor and each Councilmember nominate one member to the Board, to be approved by the Council. The two remaining positions are open to nominations by the Mayor and entire Council, then approved by the Council.

Board members may serve two (2) consecutive terms and may be reappointed after a minimum three-year break in service.

The term for Rachel McCrary is scheduled to expire on December 30, 2024. The term for the new appointment will be from December 31, 2024 – December 30, 2027. This will be Councilmember Ezell's nomination.

Brian Williams
Mayor

Esther Haynes
Vice Mayor

Jacky Cagle
Councilmember

Andrea Witt
Councilmember

David Tyler
Councilmember

J. Scott Miller
City Manager

AGENDA MEMORANDUM
INTERLOCAL AGREEMENT POLICE AND FIRE SERVICES
CITY OF EAST RIDGE, TN AND CITY OF RIDGESIDE, TN

December 12, 2024

Submitted By:



J. Scott Miller, City Manager

SUBJECT:

The City of East Ridge, TN and the City of Ridgeside, TN entered into two (2) interlocal agreements dated June 24, 2021 for the City of East Ridge (1) to provide police protection services to Ridgeside and (2) to provide fire protection services to Ridgeside.

Pursuant to the “cost of service” section of each agreement, the parties agreed to a four percent (4%) increase in the cost of service for year two (fiscal year July 1, 2022 to June 30, 2023) and a four percent (4%) increase in the cost of service for year three (fiscal year July 1, 2023 to June 30, 2024). There was no provision for a continued increase in the cost of service for fiscal years after June 30, 2024.

Pursuant to the “renewal and termination” section of each agreement “this agreement shall automatically renew for additional one (1) year terms beginning July 1 of each respective term unless notice to terminate is given to the non-terminating party on the giving of such written notice to terminate not less than six (6) months prior to the end of such respective term.”

Since these agreements are automatically renewed every fiscal year and there was no provision for a cost of service increase after June 30, 2024, I worked with the Mayor of the City of Ridgeside in developing addendums to the Police and Fire Interlocal Agreements that employed a four percent (4%) increase for fiscal year July 1, 2024 to June 30, 2025. Said addendums were ultimately approved by both governmental entities. I propose that the City initiate similar addendums to the Police and Fire Interlocal Agreements and add a four percent (4%) increase for fiscal year July 1, 2025 to June 30, 2026.

For the current fiscal year 2024-2025 (July 1, 2024 to June 30, 2025) the City of Ridgeside is paying the City of East Ridge the amount of \$83,368 for Police services and \$37,901 for Fire services.

My office has not yet received the executed addendums from the City of Ridgeside; therefore, this agenda item will be pushed to the December 12, 2024 regular business meeting.

JSM/